

OCTAGON PACKER RECEIVER

Octagon Receivers are engineered to withstand the repeated pressures and abuse of compactors. Designed to provide **LONG-LASTING, DEPENDABLE** performance for high-volume refuse accounts.

Compatible with
most major brand
roll-off systems



FEATURES AND BENEFITS

- 7 gauge floor with 3" structural channels on 18" centers
- 7 gauge lower front and sides
- 10 gauge upper front and sides
- ANSI-compatible opening
- Painted any standard color
- Several sizes and hookup options available

"E" models (Extended Wear) include 1/4" container floor and fully welded (inside/outside) container sidewalls

OCTAGON PACKER RECEIVER

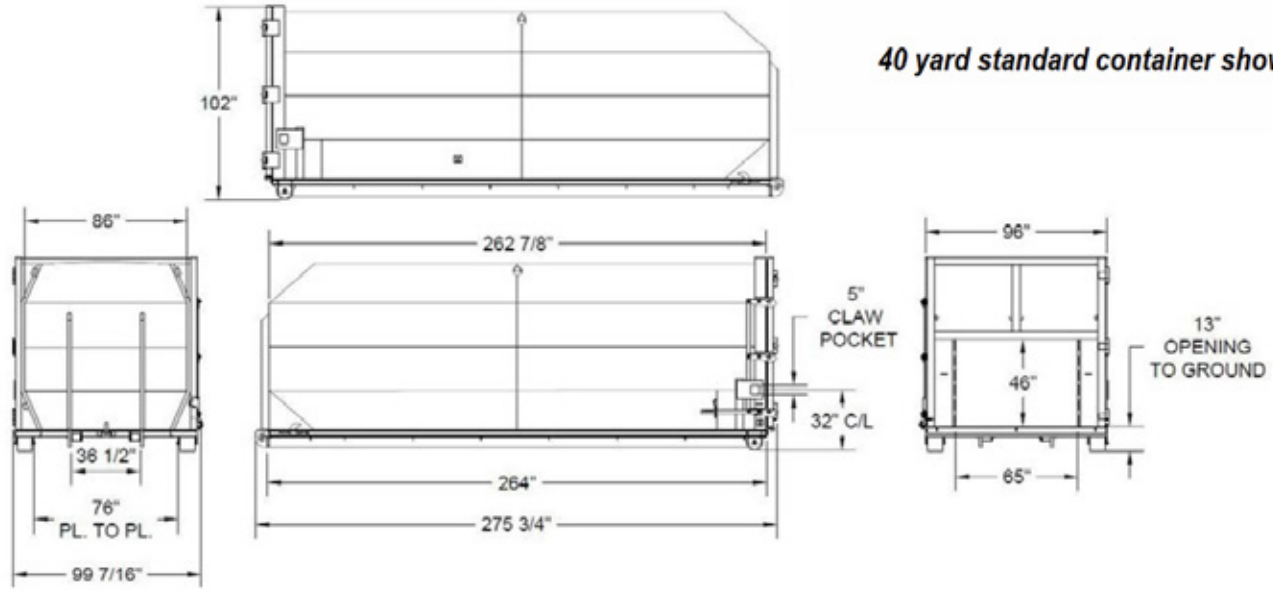

40 yard standard container shown

Outside Dimensions				Rated Capacity Cubic Yards	Approximate Shipping Weight
Description	Length	Width	Height		
20-Yard OCT	15'	100"	86"	20	4,600 lbs.
30-Yard OCT	17' 7"	100"	101"	30	5,500 lbs.
40-Yard OCT	23'	100"	102"	40	7,024 lbs.

Options

Front wheels

Belly bands

Crash plate

Ratchet binder in place of standard latch

HD or XHD specs. available for larger compactors

Painted any standard color- special colors available upon request

Standard Specifications

Floor: 7 gauge with 3" structural channels on 18" centers and 6" x 2" x 3/16" structural tubing main rails

Standard: 40 yard has maximum payload of 60,000 lbs. and a maximum force rate of 70,000 lbs. ANSI-compatible opening 13" to ground. 46" tall X 65" wide opening. Other sizes available.

Standard Color Choices*



Colors shown are as accurate as printing allows. The actual color is subject to variation from the printed color sample. Color choices vary by plant location. Please contact your local sales representative for available colors. Custom colors are available upon request and are subject to an additional charge.



Tel: 877.468.9278 | sales@wastequip.com | www.wastequip.com

Wastequip is the leading North American manufacturer of waste and recycling equipment for collecting, processing and transporting recyclables and solid or liquid waste. December 2016 © Wastequip, all rights reserved. Specifications subject to improvement without notice. Equipment displayed should be operated by properly trained personnel. Operators should become familiar with OSHA, ANSI and any other applicable standards or laws for using this equipment. Improper use, misuse, or lack of maintenance could cause injury to people and/or property. Photos used in the literature are illustrative only. We assume no liability or responsibility for proper training/operation of equipment not manufactured by Wastequip. We reserve the right to make changes at any time without notice. Information contained within this literature is intended to be the most accurate available at time of printing.