

# ACCU-PAK VERTICAL COMPACTORS

D-400, D-600 & D-800

**Designed for restaurants, motels, grocery stores, apartment complexes or other locations where space is limited.**

With a 30-second cycle time, the Accu-Pak compactor with a patented 4-in-1 head design is the only vertical compactor in the industry that can be changed to front, rear, left or right feed in the field.



Available with 3, 4, 6 or 8 yard front load containers.  
D-800 model designed to be loaded from dock or stand.  
D-300 container comes with casters.



## Value Added Benefits

<b>Improved efficiency</b>	<ul style="list-style-type: none"><li>• Quick cycle times improve employee efficiency; trash is compacted in just 30 seconds.</li></ul>
<b>Increased performance</b>	<ul style="list-style-type: none"><li>• 18" of ram penetration and over 28,000 lbs. of ram force ensure maximum compaction.</li></ul>
<b>Standard features included at no additional charge</b>	<ul style="list-style-type: none"><li>• Patented 4-1 head can be changed to feed from front, rear, left side or right side.</li><li>• Full Container Light alerts you when trash is ready for pickup.</li><li>• Magnetic interlock prevents the compactor from operating if door is open or container is not properly in place.</li><li>• Low temperature oil feature works well in hot or cold climates.*</li><li>• Driver light is illuminated when it is safe for the hauler to remove the container.</li><li>• Built-in stops hold container in place to prevent movement during compaction.</li></ul>
<b>Ease of ownership</b>	<ul style="list-style-type: none"><li>• Purchase, rental and leasing programs available.</li></ul>
<b>Strong warranty</b>	<ul style="list-style-type: none"><li>• 1-1-1 warranty (1-year structural, 1-year parts and 1-year labor).</li></ul>

\*Use of an oil heater or extreme cold weather hydraulic oil is recommended in extreme cold conditions.



# ACCU-PAK VERTICAL COMPACTORS

## Standard Features

- Short 30 second cycle time
- Full container light
- Low temperature oil
- Operational and service manual
- Primed and painted in several colors

## Optional Features

- Chute extension
- Loading platform with safety rail
- Through the wall installation
- Thermostat oil controlled heater
- Automatic odor suppression system
- Biodegradable oil
- Single phase 220 volt or 110 volt available

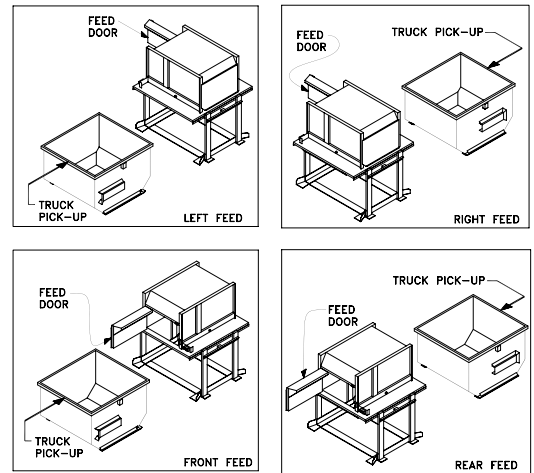
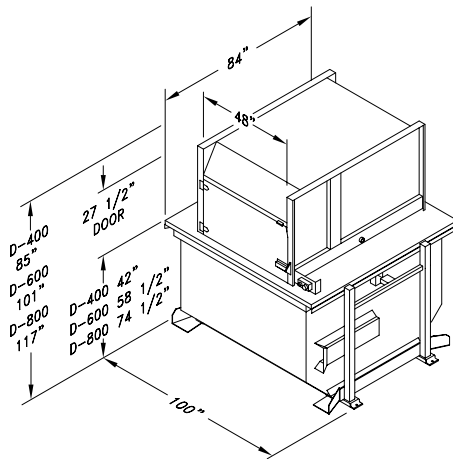

## SPECIFICATIONS



Replacement parts available online at [www.gotoparts.com](http://www.gotoparts.com).

### Charge Box

- Wastequip rating: 0.5 cu. yds.
- Wastec rating: 0.42 cu. yds.
- Compactor weight with stand and container
- 3,340 lbs. (D-300 / 3-yard)
- 3,540 lbs. (D-400 / 4-yard)
- 3,740 lbs. (D-600 / 6-yard)
- 3,940 lbs. (D-800) / 8-yard)

### Ram

- Ram height: 36"
- Ram penetration: 18.00"
- Face plate: 7-gauge, 48"W x 36"H
- Base plate: 7-gauge, 47-1/2"W x 36"
- Side plates: 7-gauge, 36"W x 19-11/16"H

### Compactor Head

- Sides: 11-gauge, (2) 83-1/2"W x 19"H
- Top deck: 11-gauge, (2) 83-1/2"W x 21"Ht

### Electrical

- Fan-cooled electric motor: 3hp
- Voltage: 208/230/460, 3-phase 60 Hz
- Power box: UL rated, TEFC housing
- Automated cycle operation: turn-key switch-ram extends, retracts and stops automatically

### Hydraulic Performance

- Pump: 2.8 gpm
- Pump type: Gear
- Hydraulic oil tank: 8.7 gallon reservoir
- Cylinder bore/rod/stroke: 4" bore, 2" rod 16" stroke
- Normal ram face pressure: 25,100 psi
- Maximum ram face pressure: 26,400 psi
- Normal ram psi: 2,000
- Maximum ram psi: 2,100
- Cubic yard per hour: 49 cu. yd./hr.
- Power unit location internal
- Cycle time: 30 seconds

### Standard Color Choices\*



\* Specifications are the same as the D-600, except where indicated.

Colors shown are as accurate as printing allows. The actual color is subject to variation from the printed color sample. Color choices vary by plant location. Please contact your local sales representative for available colors. Custom colors are available upon request and are subject to an additional charge.



Tel: 877.468.9278 | [sales@wastequip.com](mailto:sales@wastequip.com) | [www.wastequip.com](http://www.wastequip.com)

Wastequip is the leading North American manufacturer of waste and recycling equipment for collecting, processing and transporting recyclables and solid or liquid waste. December 2016 © Wastequip, all rights reserved. Specifications subject to improvement without notice. Equipment displayed should be operated by properly trained personnel. Operators should become familiar with OSHA, ANSI and any other applicable standards or laws for using this equipment. Improper use, misuse, or lack of maintenance could cause injury to people and/or property. Photos used in the literature are illustrative only. We assume no liability or responsibility for proper training/operation of equipment not manufactured by Wastequip. We reserve the right to make changes at any time without notice. Information contained within this literature is intended to be the most accurate available at time of printing.