

THE BENEFITS OF
COMPACTION

SAVES MONEY • IMPROVES SAFETY • ENHANCES AESTHETICS • INCREASES USABLE SPACE



Tel: 877.468.9278 | www.wastequip.com

WHO NEEDS A COMPACTOR?

Compacting waste reduces the size and volume of material through compressing and crushing. This reduces the number of hauls, saving money.

Not all generators of solid waste and recycling material can justify compaction equipment. A business with one 6 cubic yard container emptied once a week may not need a compactor. Larger volume waste and recycling generators are more likely prospects. A generator of 30 to 40 cubic yards of material weekly might justify a vertical compactor. One that generates 60 to 150 cubic yards weekly could use a stationary compactor with a detachable container or a self-contained liquid-tight compactor.

COMPACTION ADVANTAGES

1 SAVES MONEY

- **Less Labor.** No need to break up boxes or carry trash outside to container.
- **Reduces Collection Costs.** Reduces the cost of transporting refuse to the disposal site. A compactor can eliminate 3 out of 4 trips.
- **Reduces Fire Hazards.** Saves on insurance costs.
- **Reduces Insect/Rodent Problems.** No need to call an exterminator.

2 IMPROVES SAFETY AND SECURITY

- **Prevents Unauthorized Access To Waste.** A sealed container keeps others from viewing any confidential data. A steel security chute prevents merchandise from being taken out the back door.
- **Avoids Unauthorized Disposal.** Prevents others from using your container for disposal of their trash or hazardous waste.
- **Discourages Scavengers.** Keeps scavengers out of your container.
- **Improves Safety.** Enclosed or chute fed compactor eliminates need for employees to take material outside.

3 IMPROVES AESTHETICS

- **Prevents Wind-Blown Trash.** Reduces need to sweep parking lots.
- **Controls Odor.** A sealed compaction system reduces odor.
- **Extends Pavement Life.** Reduces wear and tear on parking surfaces by heavy collection vehicles.

4 INCREASES USABLE SPACE

- **Saves Inside Storage Space.** No need to use storeroom space for refuse.
- **Saves Outside Parking Space.** Fewer containers outside means more customer parking spaces.

TYPES OF COMPACTORS



Stationary

WASTE TYPE: Dry waste including mixed paper, corrugated, wood, plastic, etc.

APPLICATIONS: Retail/department stores, industrial, warehouses

SIZES: 2 – 15 cubic yard stationary is attached to a 40 cubic yard container



Pack-Man

WASTE TYPE: Primarily wet waste and food waste with a few dry applications

APPLICATIONS: Fast food, restaurants, nursing homes, small grocery stores

SIZES: 3, 4, 6 and 8 cubic yard units



Self-Contained

WASTE TYPE: Wet waste including food processing, medical, etc.

APPLICATIONS: Supermarkets (produce/meat waste), restaurants, malls, hospitals

SIZES: 20, 30, 35 cubic yard self-contained

HOW

A COMPACTOR WORKS?

A compactor consists of 5 basic parts:

1. The Body is a steel structure which houses all the other parts. It has an area where material is compiled or **CHARGE BOX** with heavily reinforced sides to withstand the forces of compaction. A **BREAKER BAR**, made of a heavy steel angle, is located across the front of the charge box. This bar breaks oversized objects like wood or pallets before they enter the compaction container

2. The Ram is a specially designed steel structure with heavy face plate. It moves horizontally through the charge box, forcing the refuse into the compaction container.

3. The Cylinder is attached behind the ram and moves it forward and backward. Inside the cylinder is a piston and rod which operates hydraulically. The cylinders vary in size. Larger ones are used in heavy-duty compactors with big charge

boxes. Cylinders are sized by bore and rod diameters.

4. The Power Unit consists of a hydraulic oil tank, pump, electric motor, and directional control valve. The oil, under high pressure, forces the piston in the cylinder to move forward and backward.

5. The Electric Panel Box contains the transformer, motor starter, relays, fuses, and switches that operate the compactor. Most panel boxes incorporate printed circuit boards or programmable controllers for added reliability. All should be UL rated.

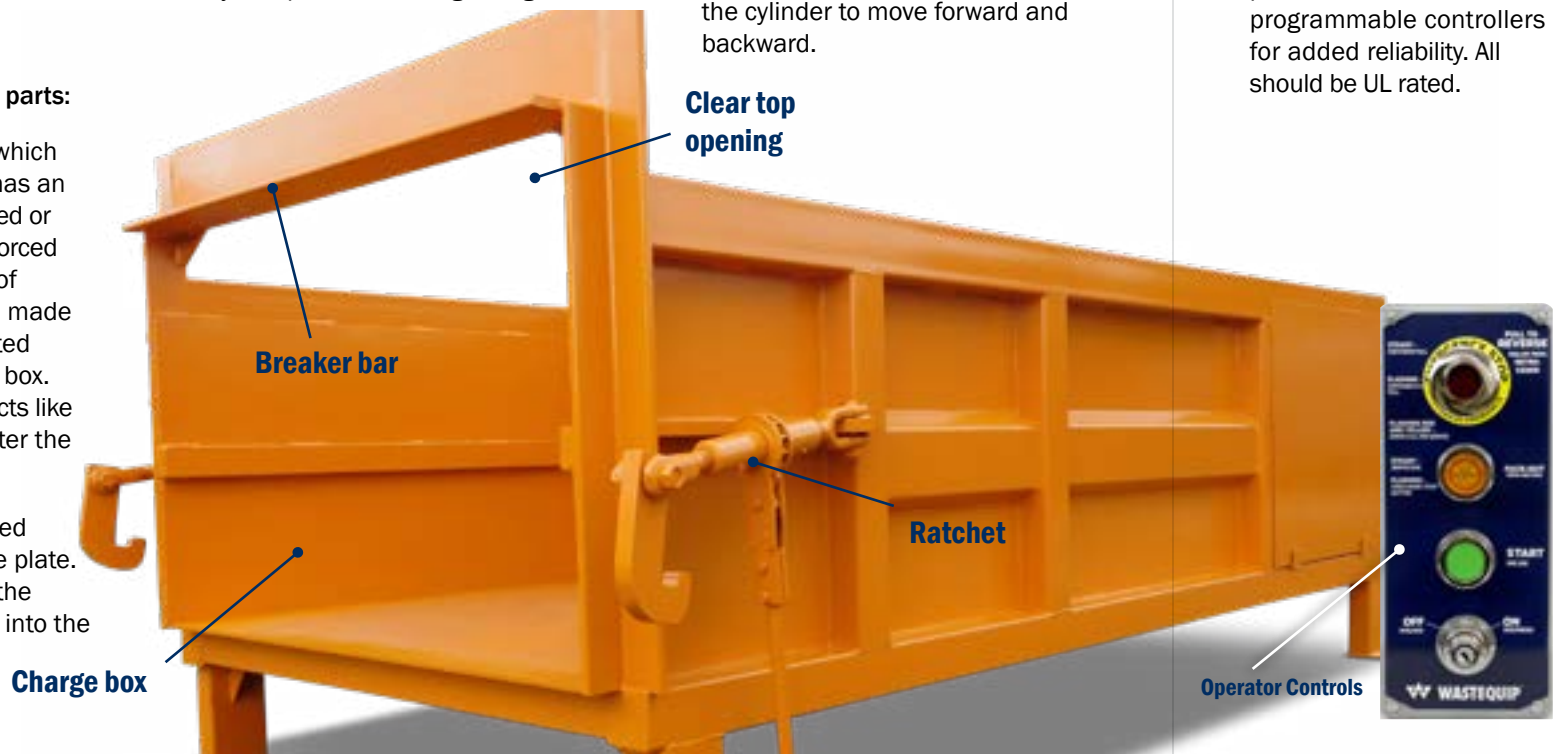

Considerations when choosing a compactor

Volume of Waste Generated Will the compactor be adequate to handle the volume generated, particularly at peak loading times?

Size of Waste What are the dimensions of the largest box, bag, etc.? Is the clear top opening large enough to accommodate these objects without bridging?

Type of Waste Dry waste is efficiently compacted by a stationary compactor. Wet waste is best handled by a self-contained, liquid-tight compactor.

Ease of Use Is the compactor conveniently located? What is the loading height? Does it save steps and labor? Is it easy to feed?

Is one central point adequate or should several locations be considered?

Available Space Is there space for the compactor and collection truck to service the compactor? Are overhead clearances adequate?

Suitable Voltage Is adequate power available? Three-phase? Single phase?

Collection Equipment Compatibility Is the compactor compatible with local waste collection equipment?

Installation Does installation require a thru-the-wall chute, a doghouse, or a dock-fed hopper? Is the compactor adaptable to these types of installations?

COMPACTION RATIO

The average compaction ratio for compactible, mixed waste is 4 to 1.

The amount by which a compactor will reduce the volume of solid waste depends on several factors:

- Type of refuse
- Total force of compaction RAM
- Type of compaction container

Example:

You could expect to compact 160 loose cubic yards of mixed waste into one 40 cubic yard container.

Exceptions to the 4 to 1 ratio:

Industrial waste consisting mainly of pallets and heavy boxes might yield only a 2 to 1 compaction ratio. Climate affects compaction ratio (frozen garbage is more difficult to compact than wet garbage). Consider ALL variables before estimating the compaction ratio for a specific application.

COMPACTION TERMINOLOGY

Compaction – Reducing the size and volume of material by compressing and crushing.

Stationary Compactor – A machine that compacts refuse into a detachable container at the site of generation.

Pre-Crusher Dry Waste Compactor – A machine that pre-crushes large bulky items such as steel drums and pallets prior to being compacted into the container.

Compaction Container – A steel reinforced container into which a stationary compactor compacts refuse.

Self-Contained Compactor – A unit in which the compactor is integrated structurally to the compaction container and the entire machine is taken to the disposal site.

Charge Box – The area, measured in cubic yards, in front of a compactor ram into which refuse is placed (L x W x H).

ClearTop Opening – The length and width of the opening above the charge box.

Cubic yard = 202 gallons
(Approximate equivalent of six 33-gallon bags or seven 30-gallon bags)

APPROACH SPECIFICATIONS

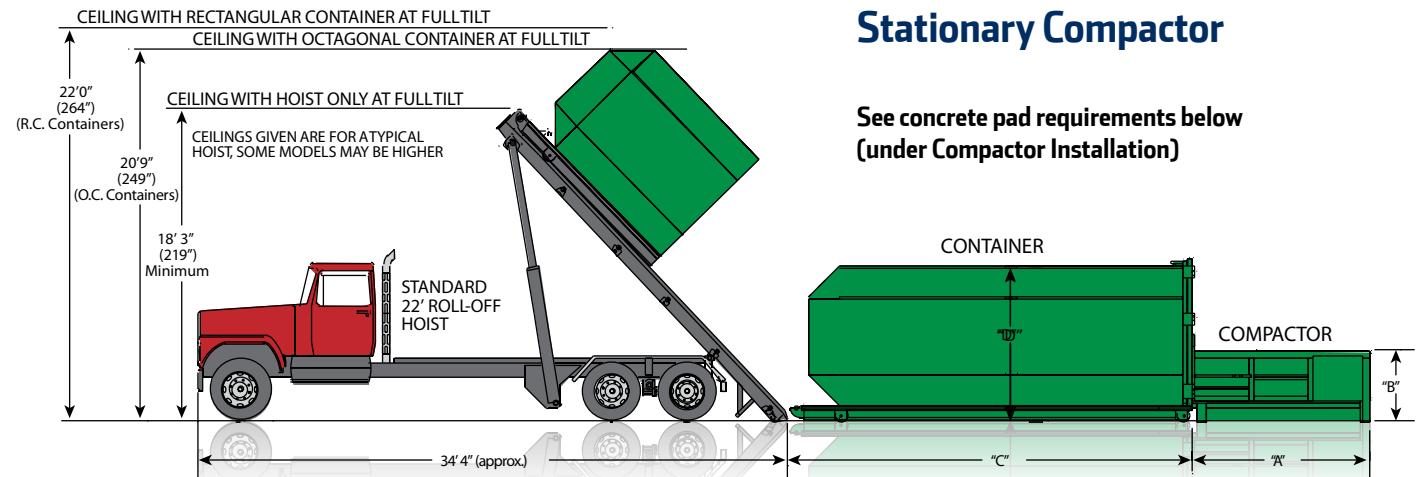

Stationary Compactor

See concrete pad requirements below
(under Compactor Installation)

	CONTAINER					COMPACTOR						
Stationary volume (cu. yd.)	25	27	30	35	40	245	345	350	445	450	550	645
Length overall (in.)	171 1/2(C)	189 1/2(C)	207 1/2(C)	237 1/2(C)	270 1/2(C)	126(A)	146(A)	187 1/2(A)	187(A)	236(A)	281(A)	263(A)
Height overall (in.)	105(D)	105(D)	105(D)	105(D)	105(D)	48 1/8(D)	48 1/8(D)	48 1/8(D)	48 1/8(D)	48 1/8(D)	49 5/8(D)	48 1/8(D)

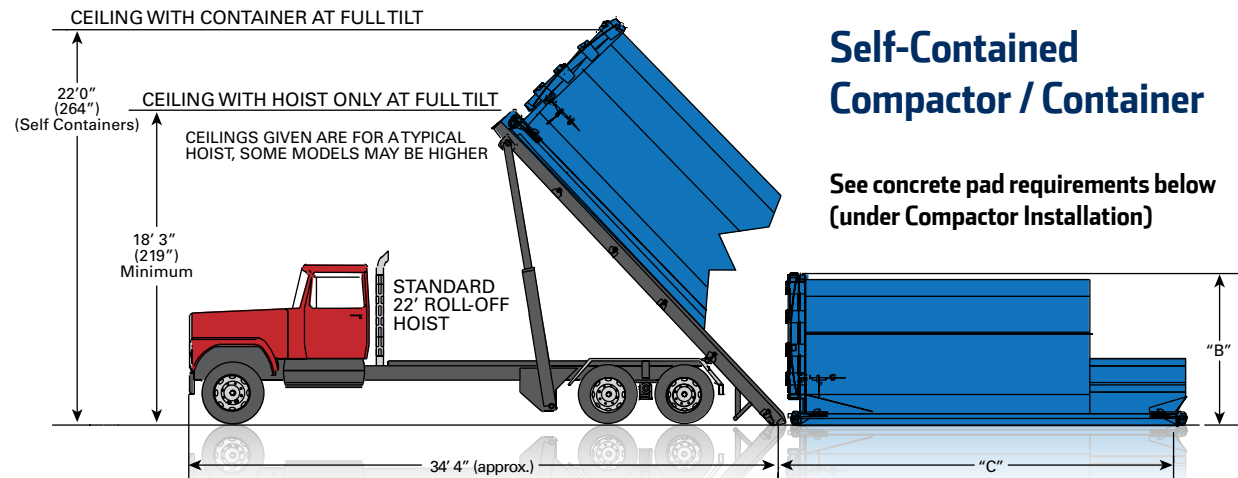

Self-Contained Compactor / Container

See concrete pad requirements below
(under Compactor Installation)

	MODEL 265IP					MODEL 265XP				
Self-contained volume (cu. yd.)	16	20	25	30	35	20	25	30	35	38
Length overall (in.)	184 1/2(C)	208 1/2(C)	238 1/2(C)	268 1/2(C)	298 1/2(C)	218(C)	218(C)	248(C)	278(C)	299(C)
Height overall (in.)	100(B)	100(B)	100(B)	100(B)	100(B)	100(B)	100(B)	100(B)	100(B)	100(B)

COMPACTOR INSTALLATION

Concrete Pad Concrete pad preferred dimensions are 10' wide and a length of 5' greater than the combined length of the compactor and container (not enclosed). Examples:

- Pad: 10' wide x 40' long for 2 cu. yd. stationary and container
- Pad: 10' wide x 35' long for 35 cu. yd. self-contained

- Pad: 10' wide x 12' long for vertical compactor

The pad should be a minimum of 3,000 p.s.i. concrete, wire mesh reinforced and 6" thick.

Electrical A lockable fused disconnect box (customer furnished) must be within sight and no more than 50' away from the main control panel.

This equipment conforms to all applicable ANSI Z245.2/.21 Safety Standards.

Safety Standards The installation must comply with recommended ANSI and OSHA standards. There must be interlock switches on the hopper access gate or chute/doghouse doors. A "Hold to Run" button may also be required.

Compaction Containers Available in octagonal and rectangular styles from 20 to 40 cu. yd.

Emergency Controls E-stop controls should be readily accessible to the operator or located within 3' of the point of operation, the material feed area, or if chute-fed, within 3' of access door.

